

# ДШ-14Л

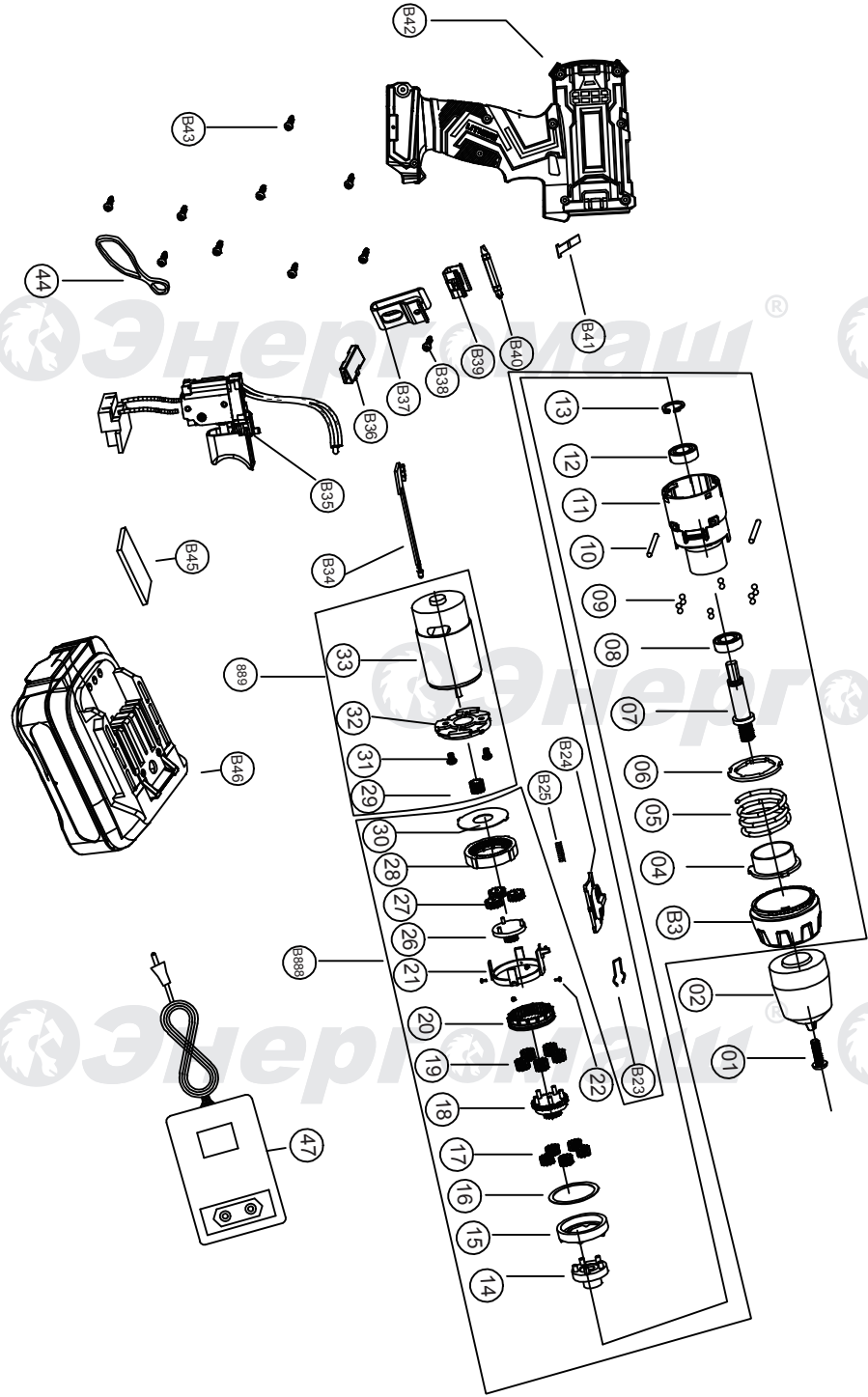

NO.	DESCRIPTION	SPEC.	NO.	DESCRIPTION	SPEC.
1	CHUCK SCREW	M5X20mm	B24	TWO SPEED CHANGE	
2	KEYLESS CHUCK	10mm		BUTTON	
B3	TORQUE		B25	SPRING	
	ADJUSTMENT RING		26	THE FIRST PLANET	
4	BIG NUT			GEAR BRACKET	
5	SPRING		27	THE FIRST PLANET GEAR	
6	WASHER	2mm	28	INNER GEAR RING	
7	SPINDLE		29	MOTOR GEAR	
8	BEARING	688Z	30	WASHER	φ34.5xφ12.5x0.5mm
9	STEEL BALL	φ4mm	31	SCREW	M3X5mm
10	GEAR BOX PIN	φ3mmX30mm	32	PRESS BOARD	
11	GEAR BOX		33	MOTOR	
12	BEARING	688Z	B34	CAPACITY DISPLAY PCB	
13	CIRCLIP	φ8mm	B35	SWITCH	
14	THE THIRD PLANET		B36	DIRECTION SWITCH	
	GEAR BRACKET		B37	BELT HOOK	
15	GEAR RING		B38	SCREW	ST3X10mm
16	WASHER	φ34xφ29x0.5mm	B39	SCREW DRIVER BITS HOLDER	
17	THE THIRD PLANET		B40	SCREW DRIVER BITS	
	GEAR		B41	SPRING	
18	THE SECOND		B42	HOUSING	
	PLANET GEAR BRACKET		B43	SCREW	ST2.9X16mm
19	THE SECOND PLANET		44	HOPE	
	GEAR		B45	MAGNET	
20	TWO SPEED CHANGE		B46	BATTERY PACK	
	GEAR RING		47	CHARGER	
21	TWO SPEED CHANGE		B888	GEAR BOX ASSEMBLY	
	PLASTIC RING		889	MOTOR ASSEMBLY	
22	RIVET	φ1.2mm			
B23	SPRING				